

# DRIMASTER 2000 and DRI 2000-3S

## Anti-Condensation & Whole House Ventilation Unit Installation and Maintenance

### Important notes to installers

The Nuair Drimaster range has been curing severe condensation problems for over 20 years in some of the worst affected properties throughout the world.

Its successful operation depends entirely upon the unit being installed strictly in accordance with these instructions.

We would, therefore, respectfully suggest that you read through this guide in its entirety before commencing installation and then go through this guide step by step to ensure a satisfactory completion.

Whilst the installation of the Drimaster unit may be achieved by a suitable craftsman, the provision of the electrical supply and the connection of the unit to the mains must be carried out by a qualified electrician.

The unit has a 5 year warranty starting from the day of delivery and includes parts and labour for the first year. The remaining 4 years covers parts only. This warranty is conditional on the following:-

- That the unit is installed strictly in accordance with this guide.
- That the unit filters are removed and cleaned or replaced at the recommended intervals.
- If a floor is higher than 4.5m the requirements in sections 3.2 and 8.1 must be followed.

The unit represents a significant financial outlay on the part of the user/specifier and the unique 5 year guarantee is important to them. We make a point of advising them that the installer is provided with detailed instructions regarding installation/guarantee registration and therefore has the responsibility of ensuring that the unit is guaranteed for the user/specifier.

Figure 1.

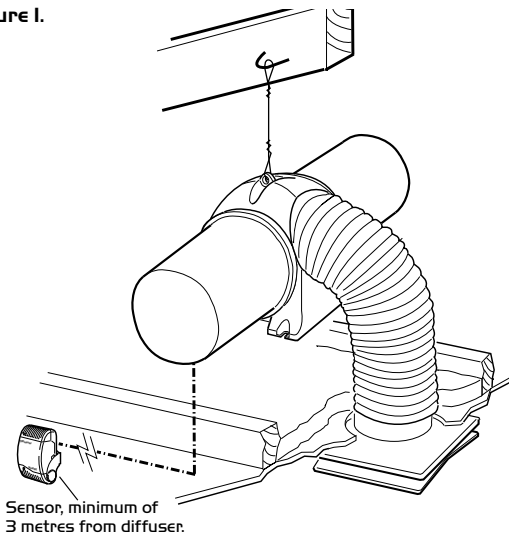

### Operation

The Drimaster provides whole home ventilation using the Positive Input Ventilation principle. Essentially the concept is to introduce fresh, filtered air into the dwelling at a continuous rate, encouraging movement of air from inside to outside.

To achieve this, the unit is mounted in the loft space, drawing air through the filters and inputting it, at ceiling level, into the property.

The Drimaster units are supplied with a remote temperature sensor that works in conjunction with the units internal sensor. This sensor continuously monitors the temperature in the loft and house,

boosting the air volume when the loft temperature is greater than the house (heat recovery mode).

If the loft temperature becomes excessive the unit will switch to standby mode (no airflow). Once installed, the airflow can be set to suit the house size and, if required, the way it responds to the temperature changes within.

### 1.0 Loft Inspection

Check to ensure that the loft has adequate ventilation. Look for ridge vents, tile vents, eaves vents and continuous air gaps etc. making sure none are blocked. In older properties these vents may not be provided. However, there should be enough 'leakage' to accommodate the requirements of the Drimaster unit. A useful way of checking such lofts is to close the hatch, switch off the lights and look for any daylight penetration. If you can see daylight it is reasonable to assume that the loft has ventilation.

There may be occasions where a loft is so well sealed that additional ventilation may have to be provided by the owner/occupier. This will not only assist the operation of the Drimaster, but will help prevent possible expensive structural damage caused by inadequate air movement in the loft itself. It should be noted that there cannot be too much ventilation into the loft.

Ensure that all water tanks are covered and sealed.

Check that all water pipes are lagged.

Ensure that any extract fans are discharging to outside and not into the loft.

Check that the loft hatch is tightly sealed.

Ensure that all holes in the ceilings are sealed i.e. ceiling light fittings etc.

A visual inspection of any flues or chimneys for leakage in the loft should be carried out by the installer.

If any leakage points are found, or if there is any doubt at all, then the installer should advise the house owner/provider as soon as possible and seek instruction from them before proceeding with the installation.

### 2.0 Siting the Diffuser position

The diffuser has a unique air throw pattern and it is essential that it is located correctly in the central hallway in single story properties or in the ceiling of the top floor landing on 2 or more storey dwellings. As can be seen in figure 2 the diffuser discharges air evenly from all four sides along the underside of the ceiling.

Figure 2. Diffuser (viewed from below).

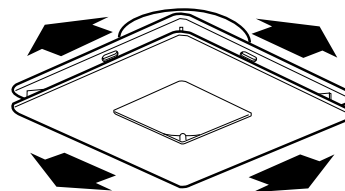

Note: The positioning of the diffuser should be in strict accordance with the table shown below to ensure correct operation:-

Airflow from four sides

Speed Setting	Minimum distance of diffuser from wall
1	100mm
2	155mm
3	400mm
4	625mm
5	850mm
6	1000mm

## Note: SMOKE ALARMS

It is also important to ensure that the diffuser is NOT placed within 1 metre of a smoke alarm.

If the diffuser cannot be repositioned, **two sides of the diffuser must be closed off** using the foam strips supplied to encourage the air through the remaining open sides that faces at least 1.5 metres of unobstructed area away from the smoke alarm sensor.

Figure 3. Fitting the 2 foam strips.

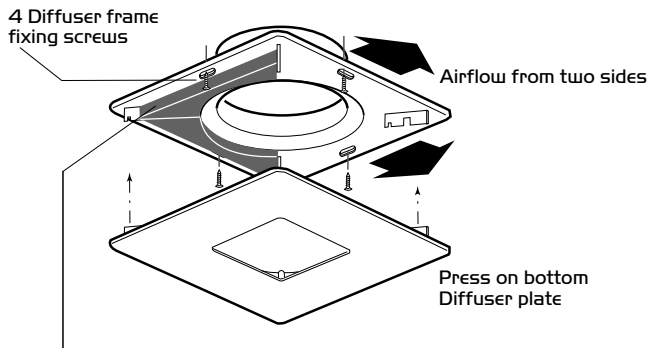

2 Foam strips (supplied) fit on any of the diffuser sides to guide airflow away from a smoke detector and/or obstructions as required.

## 3.0 Fitting the Diffuser

### 3.1 Plastic Type

Cut a circular hole 225mm diameter in the ceiling between two convenient joists. Position the diffuser frame and secure it to the underside of the ceiling with the 1 1/2" x 8 csk. hd. screws and plugs provided.

Attach the diffuser plate to the frame using the four built in press on clips provided. Foam strips should also be used as required when this method of installing the diffuser is used.

### 3.2 Painted aluminium type c/w intumescent fireblock

Cut a 200mm hole in ceiling and align the top portion of unit (A) above the ceiling over the hole.

Position the central ceiling plate (B) on the ceiling in the room ensuring the the central hole is aligned with the hole in the ceiling. Use the 4 MS X 35mm screws to fix (B) to (A) through the 4 studs positioned on the upper side of (B).

Screw bottom part of the unit (C) to the the ceiling plate (B) through the plastic spacers and into the 2 studs positioned on the upper side of (A).

Figure 4.

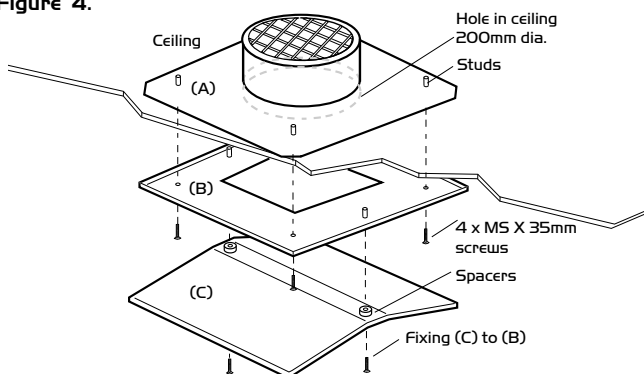

Note: Due to the higher air resistance of the fireblock, the speed of the unit should be increased by one increment for the particular property (see 12.0 speed setting).

## 4.0 Fitting the filters to the unit

The filter has a push fit rim to attach itself to the main body of the unit.

Offer the filters up to the unit and apply a small amount of pressure to the filters rim (by hand). The filter will clip into place.

The unit can then be attached to the roof via the chain (or fixed to the floor joists using the optional anti vibration mounting kit).

## 5.0 Fitting the Drimaster Unit

The standard method of installation is suspended from a convenient roof beam via the cord/chain supplied. (Note: unit weight = 3.2 kg).

Figure 5. Standard method of fixing.

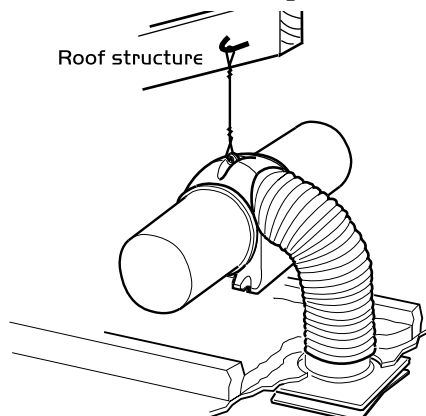

The method of locating the wire to the roof timber is the responsibility of the installer.

The flexible ducting fitted to the fan unit is connected to the outlet diffuser spigot by securing the end over the spigot using the tie band supplied. Ensure all duct joints are air tight.

## 6.0 Optional AV mounting

The AV kit contains all the parts necessary to complete a joist mounted installation. If this option is required the kit can be purchased direct from Nuaire using the following code number: 771393.

Lower the unit with the battens attached onto the joists (see Figure 6). Mark and drill the 12mm dia. clearance holes required in the ends of the battens (not supplied). Figure 7. shows a sectional view of the fixing.

Figure 6. Optional method of fixing. (AV mounting kit onto roof joists).

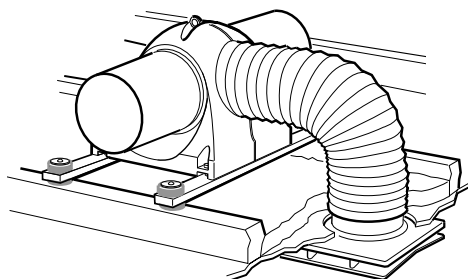

Place anti-vibration mounts above and below each batten fixing point and, using the 4 large screws and special washers, fix the unit to the joists.

**Do not overtighten the fixings. The distance from the top washer to the joist when installed must not be less than 50mm.**

Figure 7. Sectional view of AV mounting.

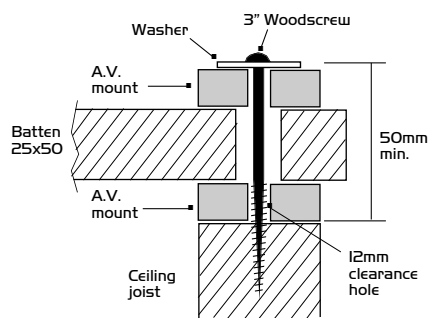

## 7.0 Filter maintenance and replacement

The filters will require no maintenance over the five year period but will need to be replaced after this period. New filters can be purchased direct from Nuair using the following code number: **775631** (five year filter). (See 17.0 How to reset LED for 5 year filters).

If the units performance has been reduced dramatically or black dust becomes visible around the outlet diffuser, check that the filter has not become dislodged in any way.

## 8.0 Electrical Connection

Please note: the electrical connection of the unit must be carried out by a qualified electrician.

### Electrical details:-

**Voltage:** 240V lph 50Hz

**Consumption:** 1.6W(min) 15.3W(max)

**Fuse size:** 1 Amp

The unit is supplied with a pre-wired power supply. This power supply unit has a metal bracket incorporating fixing holes, which should be used to fit the power supply to a suitable surface e.g. a wooden joist.

The fan unit is also supplied with a fused spur. The two core mains cable from the power supply should be connected to a fixed wiring installation, via the isolator, via the spur, in accordance with current IEE wiring regulations.

### 8.1 Smoke /Carbon monoxide alarm automatic shut down

If the unit is required to switch off in the event of smoke/CO detection, alarms are available with separate relay bases from companies such as:

**Dicon Safety products** – [www.diconsafety.co.uk](http://www.diconsafety.co.uk)

**Aico Ltd** – [www.aico.co.uk](http://www.aico.co.uk)

**Note:** This is a mandatory requirement for all 35 units.

#### Figure 8. Typical wiring

(refer to manufactures own specific instructions)

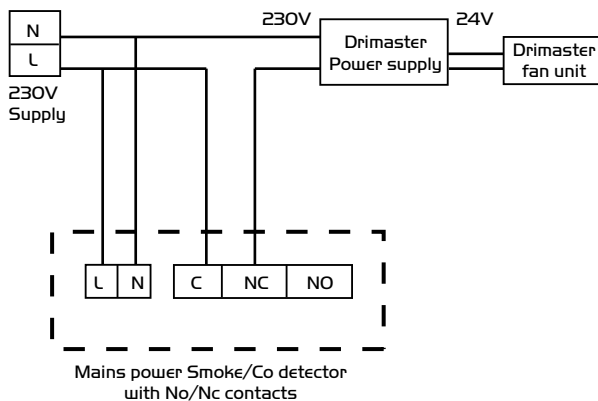

### IMPORTANT

For good EMC engineering practice, the Drimaster power supply output cable and any sensor cables should not be placed within 50mm of other cables.

## 9.0 The Remote Sensor

The DRI 2000 units are supplied with 15 metres of 2 core cable pre wired and ready to connect to the Remote Sensor (figure 9). The Remote Sensor is used in conjunction with the units internal sensor to allow the system to operate in "Heat Recovery Mode".

Figure 9. Remote Temperature Sensor.

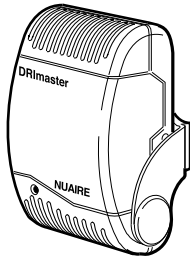

The sensor is fitted with an LED indicator which is capable of providing various status information if required.

As supplied the LED provides only the default setting of flashing RED after 5 years from commissioning to indicate that the filters need cleaning or replacement and permanent RED to indicate a failure.

Two other indications are available by closing the sprung gate latch (see figure 11). These are: GREEN to indicate when the system is in 'Heat Recovery Mode' and AMBER which indicates normal operation.

If it is desired to disable the LED function completely the LED itself may be 'bent' over to one side in order to render it 'blind' to the user.

## 10.0 Siting the Remote Sensor

The Remote Temperature Sensor incorporates a clip-in fixing bracket which can be removed for easy fitting to a suitable surface. (figure 12).

- Select a suitable location for the sensor e.g. close to ceiling height in a bedroom or hallway BUT NOT WITHIN 3 METRES of the diffuser.
- Arrange the connecting cable in position. Leave approx. 75mm of the cable free at the mounting point to ease the connection of the cable. (figure 10).
- Carefully separate the sensor from the fixing bracket using a small screwdriver (figure 11).
- Fix the bracket to the wall and arrange the end of the cable to fall through the slot cut in the bracket (figure 12).
- Carefully separate the two sensor halves to reveal the wiring connection terminals. (figure 13).
- Feed the twin cable through the cut out rear half and connect the two wires to the terminals.
- Reassemble the sensor body halves.
- Clip the sensor body in the fixing bracket arms and adjust the sensor body to the desired position.

Figure 10.

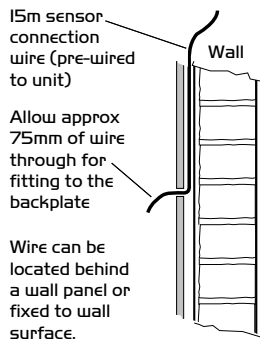

Figure 11.

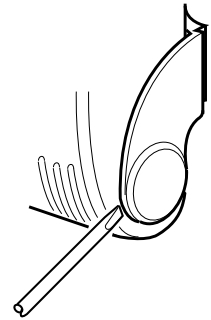

Figure 12.

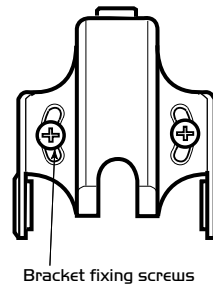

Figure 13.

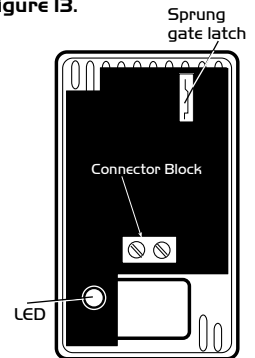
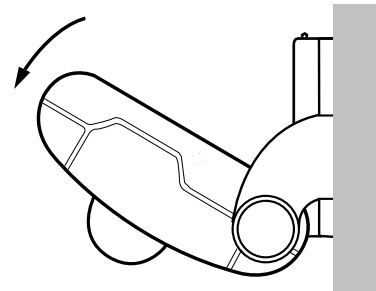

Figure 14.



## 11.0 Optional 'BOOST' facility

The unit air volume can be manually boosted to maximum speed by wiring in a simple one way switch (Part No. 773532) into the wire supplying the sensor (figure 15). By switching the unit to 'BOOST' all other functions are over-riden.

Figure 15. Wiring for boost switch.

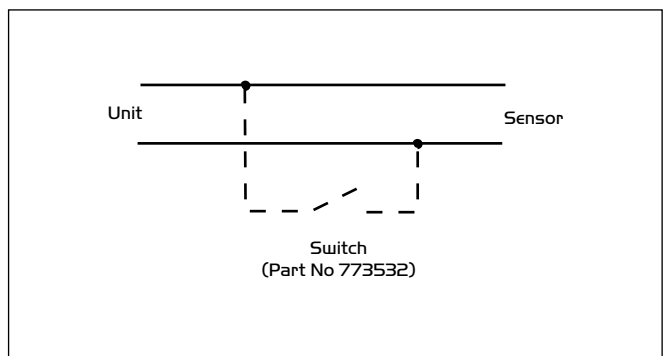

## 12.0 Speed Settings

The unit has 6 Air Volume (speed) settings. The setting switch is located on the side of the unit. Fig. 16 shows the LED's that, when illuminated, indicate the corresponding Air Volume from the unit. As an example, for a one bedroom bungalow, the unit should be set onto the lowest setting (two lights on left). A five bedroom detached house would need to be set on the highest speed (all three LED's illuminated).

Figure 16. Setting Switch/indicator panel on unit.

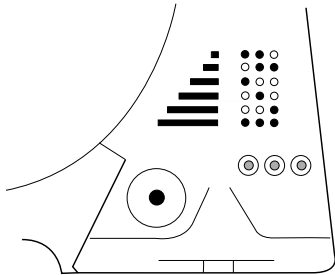

## 13.0 Selecting the Speed

When power to the unit is switched on (via the supplied isolator) the three LED's will flash simultaneously. Press the setting button once and let go. The unit will start to run. You can now press the button to sequence through the available speeds.

## 14.0 Temperature Default Settings

When delivered the unit is set to a factory default setting that will allow the unit to operate for general applications (Option 1).

When power to the unit is switched on (via the supplied isolator) the three LED's will flash simultaneously for a period of 2 minutes. The unit will then settle to the default set at the factory. The LED's will cease to flash and the default setting LED's will remain illuminated showing the default speed.

## 15.0 Selecting the alternative Temperature Control Options

When power to the unit is switched on (via the supplied isolator) the three LED's will flash simultaneously and the unit will function at boost speed for a period of 2 minutes. (This allows the installer to get from the switch to the Drimaster Unit before it starts on it's default setting).

With the LED's still flashing, press the setting button and hold it down. The LED's will run through their sequence (LED's change every 4 seconds) and you can now select the Temperature Control Function removing your finger from the button when the centre and right hand LED's are both illuminated. (See fig 17).



Figure 17. LED's showing Temp Control function selected.

## 16.0 Temperature Control options

### IMPORTANT

To select the option required, scroll through the Control Options until the desired Option is illuminated. Now SWITCH OFF at isolator, Wait for LED's to extinguish (approx 10 seconds) then SWITCH ON. This action stores the chosen option in the unit's memory.

## Setting the option

The Temperature Control Function has 5 options:

### Option 1 (Default)



At loft temperatures below 19°C the unit will operate on "Normal Operation Mode" At loft temperatures above 18°C but less than 24°C, the unit will switch automatically to "Intelligent Heat Recovery Mode" At loft temperatures above 23°C the unit will switch itself automatically to "Standby Mode".

### Option 2



At loft temperatures below 19°C the unit will operate on "Normal Operation Mode" At loft temperatures above 18°C but less than 31°C, the unit will switch automatically to "Intelligent Heat Recovery Mode" At loft temperatures above 30°C the unit will switch itself automatically to "Standby Mode".

### Option 3



This option removes the temperature sensing function out of the unit. On this option the unit will operate continuously in 'Normal Operation Mode' depending on the volume control setting selected.

### Option 4



At loft temperatures below 16°C the unit will operate on "Normal Operation Mode" At loft temperatures above 15°C but less than 28°C, the unit will switch automatically to "Heat Recovery Mode" At loft temperatures above 27°C the unit will switch itself automatically to "Standby Mode".

### Option 5



At loft temperatures below 19°C the unit will operate on "Normal Operation Mode" At loft temperatures above 18°C but less than 24°C, the unit will switch automatically to "Heat Recovery Mode" At loft temperatures above 27°C or below 5°C the unit will switch itself automatically to "Standby Mode".

### Notes:

Speed Setting 1 is not available for Temperature Control Option 5. On selecting Temperature Control Option 5, Speed Setting 1, the unit will operate as Speed Setting 2.

**Do not use this option if an integral optional heater has been fitted.**

## 17.0 How to reset LED for 5 year filter

- Isolate power the by removing fuse from the spur.
- Power the fan by replacing the fuse. (The LED's on the fan will flash simultaneously almost like a 'knight rider' type of effect for approx 2 minutes).
- During the 2 minutes hold down the setting button. (LED's will now flash in various sequences every 5 seconds).
- Wait until the left hand LED is illuminated on its own then release the button.
- Wait for approx 1 minute for timer to count down.
- Isolate power again and wait another minute ensuring LED's are extinguished (this stores the rest into the fan memory).
- Replace the fuse and choose your desired speed setting.

## CONGRATULATIONS!

### Your home has been fitted with a Nuaire Drimaster Home Improvement Unit

#### Users Guide

**Q. What is a Nuaire Drimaster Home Improvement Unit?**

A. It is a small, loft mounted, air cleaning/moving device that continuously inputs filtered fresh air into the dwelling from outside. The only 'visible' component when installed is the central input diffuser which is usually located in the central hallway/stairwell ceiling.

**Q. What does the unit do?**

A. The unit will cure and/or prevent the problems associated with condensation in your home, providing a cleaner, healthier living environment for all occupants. The unit will prevent mould growth on walls, ceilings, furniture, clothes and curtains. The unit also eradicates the musty smells evident in homes with severe condensation problems.

**Q. How does it work?**

A. Simply and very efficiently. Outside air is drawn into the loft where it is slightly warmed by the free heat in the loft caused by solar radiation and the heat lost from the property into the loft. This air is drawn into the unit, filtered and then ducted into a central area (typically the hallway / stairwell) of the dwelling. As the air is supplied into the dwelling it mixes with the warmer air that naturally accumulates at ceiling level taking advantage of the heat from this warm air you have paid for but are not making use of. This tempered, fresh, clean air then continuously and gently dilutes, displaces and replaces the air within your home. The result is a home free from serious condensation and a more pleasant and comfortable environment.

**Q. How much does it cost to run?**

A. When you consider the advantages the unit will provide for you and the other occupants, the running costs are insignificant. It should be remembered that the unit is making use of heat in both the loft and at ceiling level that would otherwise be lost. Note: the unit will switch itself off when temperatures are such that condensation would not occur within your home i.e. in summertime.

**Q. How do I operate the unit?**

A. You don't. The unit is completely automatic, switching from 'normal' to 'boost' and 'off' as required to make optimum use of energy

**Q. What maintenance is required for the unit?**

A. Very little. The only maintenance required is the replacement of the filters every 5 years. (The filter can also be vacuum cleaned periodically if necessary).

**Q. How will I remember to clean the filters?**

A. When the filters become dirty, the unit does not input as much air into the dwelling, Condensation and musty smells may become evident. This will be a signal for you to check and clean or replace the filters as necessary.

**Q. How will I know if the unit is working?**

A. The unit motor may be almost inaudible but you should notice a change of atmosphere in the hallway within a day or so. Within a few weeks any mould should start to dry out and eventually become a grey powder which can easily be cleaned. After a month your home will be a healthier environment free from severe condensation dampness and probably more efficient.

**Q. What do I do if the unit stops working?**

A. If the unit appears to have stopped working and there are no related condensation problems, then it is likely that the unit has switched itself off automatically to save energy, for example, in summer. If however, the unit is not working and there is evidence of condensation please contact our:

### Customer Services Department on 02920 858 585

If you are a Housing Association or Local Authority tenant however, you should contact your Local Housing Office in the first instance.

**The installation must only be examined by a qualified electrician and must always be isolated before an inspection. Under no circumstances must the unit be dismantled as this will invalidate the warranty.**

#### Useful tips

To ensure you get the maximum benefit from your Nuaire Drimaster Unit:

1. Avoid drying clothes on radiators or indoor clothes lines.
2. Avoid having tumble dryers venting into your home. Always vent to outside.
3. Avoid using portable unflued gas heaters.
4. Avoid using paraffin heaters.

**Finally, thank you for taking the time to read this short user guide. If you are happy with your Drimaster Home Improvement Unit, please tell your friends and neighbours.**

**If you are not - Please tell us!**

## DECLARATION OF INCORPORATION AND INFORMATION FOR SAFE INSTALLATION, OPERATION AND MAINTENANCE

We declare that the machinery named below is intended to be assembled with other components to constitute a system of machinery. All parts except for moving parts requiring the correct installation of safety guards comply with the essential requirements of the Machinery Directive. The machinery shall not be put into service until the system has been declared to be in conformity with the provisions of the EC Machinery Directive.

**Designation of machinery:** DRIMASTER 2000/2000-35

**Machinery Types:** Anti-condensation and whole house ventilation unit



**Relevant EC Council Directives:** 2006/42/EC (Machinery Directive)

**Applied Harmonised Standards:** BS EN ISO 12100-1, BS EN ISO 12100-2, EN60204-1, BS EN ISO 9001, BS EN ISO 13857

**Applied National Standards:** BS848 Parts 1, 2.2 and 5

Note: All standards used were current and valid at the date of signature.

**Signature of manufacture representatives:**

Name:	Position:	Date:
1) C. Biggs 	Technical Director	8. 07. 11
2) A. Jones 	Manufacturing Director	8. 07. 11

## INFORMATION FOR SAFE INSTALLATION, OPERATION AND MAINTENANCE OF NUAIRE VENTILATION EQUIPMENT

To comply with EC Council Directives 98/37/EC Machinery Directive and 2004/108/EC (EMC).

To be read in conjunction with the relevant Product Documentation (see 2.1)

### 1.0 GENERAL

- 1.1 The equipment referred to in this Declaration of Incorporation is supplied by Nuairé to be assembled into a ventilation system which may or may not include additional components.  
The entire system must be considered for safety purposes and it is the responsibility of the installer to ensure that all of the equipment is installed in compliance with the manufacturers recommendations and with due regard to current legislation and codes of practice.

### 2.0 INFORMATION SUPPLIED WITH THE EQUIPMENT

- 2.1 Each item of equipment is supplied with a set of documentation which provides the information required for the safe installation and maintenance of the equipment. This may be in the form of a Data sheet and/or Installation and Maintenance instruction.
- 2.2 Each unit has a rating plate attached to its outer casing. The rating plate provides essential data relating to the equipment such as serial number, unit code and electrical data. Any further data that may be required will be found in the documentation. If any item is unclear or more information is required, contact Nuairé.
- 2.3 Where warning labels or notices are attached to the unit the instructions given must be adhered to.

### 3.0 TRANSPORTATION, HANDLING AND STORAGE

- 3.1 Care must be taken at all times to prevent damage to the equipment. Note that shock to the unit may result in the balance of the impeller being affected.
- 3.2 When handling the equipment, care should be taken with corners and edges and that the weight distribution within the unit is considered. Lifting gear such as slings or ropes must be arranged so as not to bear on the casing.
- 3.3 Equipment stored on site prior to installation should be protected from the weather and steps taken to prevent ingress of contaminants.

### 4.0 OPERATIONAL LIMITS

- 4.1 It is important that the specified operational limits for the equipment are adhered to e.g. operational air temperature, air borne contaminants and unit orientation.
- 4.2 Where installation accessories are supplied with the specified equipment eg. wall mounting brackets. They are to be used to support the equipment only. Other system components must have separate provision for support.
- 4.3 Flanges and connection spigots are provided for the purpose of joining to duct work systems. They must not be used to support the ductwork.
- 4.4 In the event of RF interference the fan may change speed. This is normal and will have no adverse effect on the fan. The speed will return to normal once the interference has subsided.

### 5.0 INSTALLATION REQUIREMENTS

In addition to the particular requirements given for the individual product, the following general requirements should be noted.

- 5.1 Where access to any part of equipment which moves, or can become electrically live are not prevented by the equipment panels or by fixed installation detail (eg ducting), then guarding to the appropriate standard must be fitted.
- 5.2 The electrical installation of the equipment must comply with the requirements of the relevant local electrical safety regulations.
- 5.3 For EMC all control and sensor cables should not be placed within 50mm or on the same metal cable tray as 230V switched live, lighting or power cables and any cables not intended for use with this product.

### 6.0 COMMISSIONING REQUIREMENTS

- 6.1 General pre-commissioning checks relevant to safe operation consist of the following:  
Ensure that no foreign bodies are present within the fan or casing.  
Check electrical safety. e.g. Insulation and earthing.  
Check guarding of system.  
Check operation of Isolators/Controls.  
Check fastenings for security.
- 6.2 Other commissioning requirements are given in the relevant product documentation.

### 7.0 OPERATIONAL REQUIREMENTS

- 7.1 Equipment access panels must be in place at all times during operation of the unit, and must be secured with the original fastenings.
- 7.2 If failure of the equipment occurs or is suspected then it should be taken out of service until a competent person can effect repair or examination. (Note that certain ranges of equipment are designed to detect and compensate for fan failure).

### 8.0 MAINTENANCE REQUIREMENTS

- 8.1 Specific maintenance requirements are given in the relevant product documentation.
- 8.2 It is important that the correct tools are used for the various tasks required.
- 8.3 If the access panels are to be removed for any reason the electrical supply to the unit must be isolated.
- 8.4 A minimum period of two minutes should be allowed after electrical disconnection before access panels are removed. This will allow the impeller to come to rest. **NB: Care should still be taken however since airflow generated at some other point in the system can cause the impeller to "windmill" even when power is not present.**
- 8.5 Care should be taken when removing and storing access panels in windy conditions.



Western Industrial Estate  
Caerphilly United Kingdom  
CF83 INA  
T: 029 2088 5911  
F: 029 2088 7033  
E: [info@nuaire.co.uk](mailto:info@nuaire.co.uk)  
W: [www.nuaire.co.uk](http://www.nuaire.co.uk)

Technical or commercial considerations may, from time to time, make it necessary to alter the design, performance and dimensions of equipment and the right is reserved to make such changes without prior notice.