

Lo-Carbon Sentinel Kinetic® Horizontal MVHR Unit

Features & Benefits

- **Manufactured in the UK**
- **Building Regulations ADF compliant**
- **SAP Appendix Q Eligible**
- **Energy Savings Trust best practice compliant**
- **Up to 85% heat recovery whilst controlling condensation**
- **Programmable Summer bypass**
- **Digital controller for simple and accurate commissioning**
- **External condensate connection**
- **Plug and play controls; Humidistat, Vent-Wise, Wireless remote**
- **LS inputs/(Light Switch)**
- **Volt-free inputs**
- **Self diagnosis for simplified fault finding**
- **Adjustable delay on/delay off timer**

The Sentinel Kinetic Horizontal Range

A wholehouse heat recovery system with up to 85% heat exchange efficiency. An easily accessible heat recovery cube protected by two removable EU3 filters. Two Lo-Carbon Energy Saving EC DC fans ensure long life (typically over double the life of AC motors) and lowest possible energy use. Fully insulated construction with built in condensation drain. Specifically designed for new build constructions with a high level of insulation.

Lo-Carbon Sentinel Kinetic meets the latest requirements of the Building Regulations ADF for wholehouse system ventilation: System 4. Continuous mechanical supply and extract with heat recovery. The Lo-Carbon Sentinel Kinetic models have 3 fully adjustable speeds and a purge setting - maximum. Supplied with the unit is a digital controller that can be used to pre-set the speeds to any required air-flow within the performance range.

Integral Humidity Sensor

The integral humidity sensor ('H' models) increases speed in proportion to relative humidity levels, saving energy and reducing noise. The sensor also reacts to small but rapid increases in humidity, even if the normal trigger threshold is not reached. This unique feature

ensures adequate ventilation, even for the smallest wet-room. Night time relative humidity setback feature suppresses nuisance tripping as humidity gradually increases with falling temperature. Acoustically lined - low noise levels from only 20dB(A) @3m.

Models

Model	Stock Ref
Kinetic 200Z	448733
Kinetic 200ZH (humidity sensor)	449540
Kinetic 300Z	447801
Kinetic 300ZH (humidity sensor)	449536

Optional Controls

Model	Stock Ref
Wireless enable kit (includes one switch)	441865
Wireless boost switch (max 3 switches)	437827
Vent-Wise Controller (also requires sensors, see Accessories & Controllers section)	441780

Multiple control options:

Five Voltfree pairs of switch terminals for sensor inputs allow boosting from a full range of Vent-Axia controllers - humidistats, PIR, timers.

Two terminals with 0-24V outputs allow 0V to 10V proportional control by sophisticated controllers such as CO₂ sensors and proportional humidistats.

The optional Vent-Wise controller senses temperature rise in a bath/shower hot water supply and/or current in a cooker/hob electrical circuit to activate boost, ensuring additional ventilation when needed. Switch-live for boosting via light switches (220-240 V AC) or manual Normal/Boost switches. This connection has the advantage of Delay-On and Delay-Off facility. Delay-On enables you to prevent the Boost airflow between 0 and 10 minutes, after a light switch has been activated. Delay-Off allows the Boost airflow to continue after a light switch is turned off to ensure effective clearance of humidity. This timer is adjustable between 0 and 25 minutes.

Summer Bypass

An internal damper is activated when the outside temperature is less than the room temperature. The damper opens allowing cooler fresh air to bypass the Heat Recovery Cell and reduce the internal temperature towards the pre-set 'Comfort Temperature'. When the inside air temperature reaches the pre set 'Comfort Temperature' the bypass damper closes. Anti-frost protection: In cold climates there is a possibility of frost building up on the intake side of the heat exchanger. In order to prevent damage, the Kinetic reduces supply flow while maintaining extract flow at temperatures below 0°C.

Specific Fan Power

	200 Hz		300 Hz	
	W/l/s	%*	W/l/s	%*
K+1	0.62	80	0.59	81
K+2	0.71	79	0.51	80
K+3	0.83	78	0.57	79
K+4			0.66	78
K+5			0.76	77
K+6			0.88	76

* Estimated

Dimensions (mm)

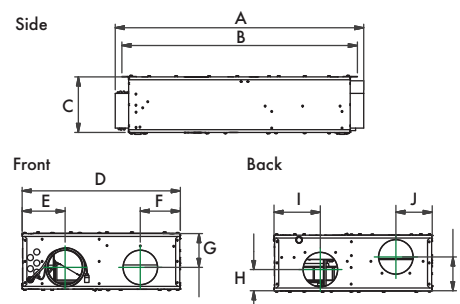

Model	A	B	C	D	E	Dia Ø
200Z	895	849	200	570	155	125
300Z	985	940	301	720	184	150
	F	G	H	I	J	K
200Z	144	122	76	167	131	122
300Z	179	187	102	279	174	108

Electrical Connection

Please note: Electrical connection should be carried out by an appropriately qualified person and in accordance with current wiring regulations.

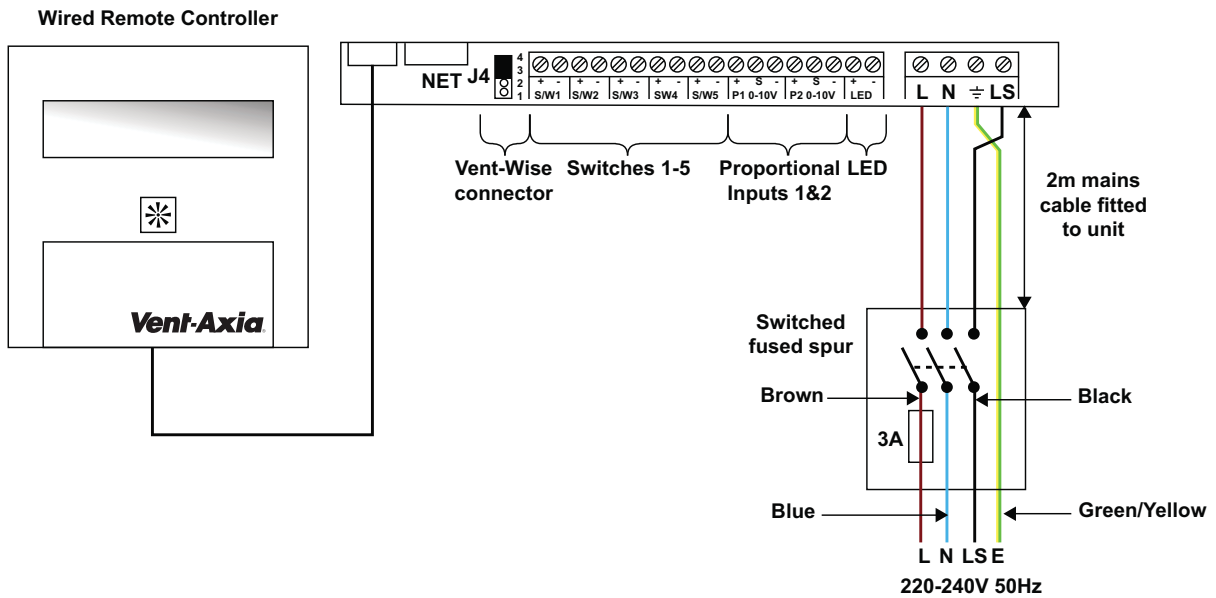

Trickle to Boost by two lighting circuits or Trickle/Boost switch

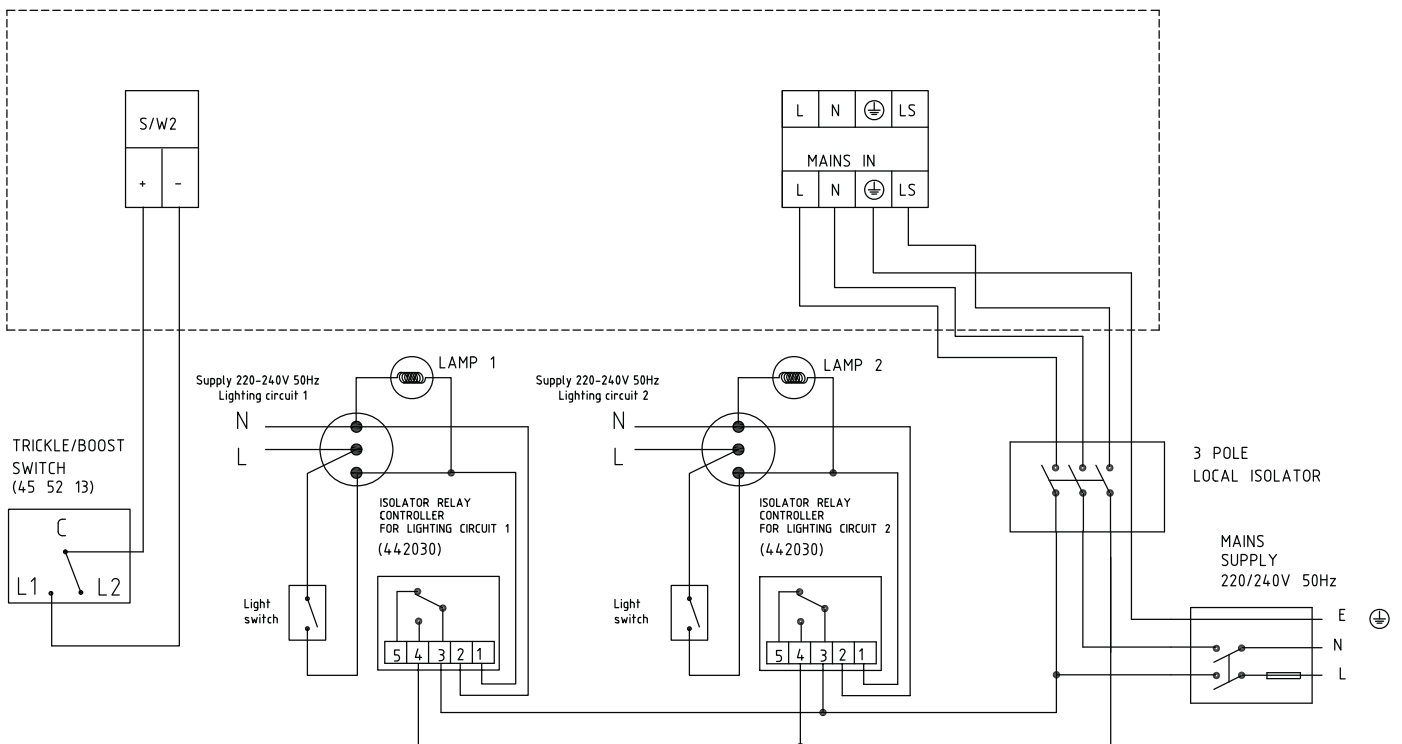

Lo-Carbon Sentinel® Kinetic Horizontal

Consultants Specification

Operation

The supply and extract ventilation unit shall be as Sentinel Kinetic Z as manufactured by Vent-Axia and shall be sized as indicated on the drawings and shall be in accordance with the particular specification; 200Z - 200mm deep, 300Z - 300mm deep.

Supply air to the room shall be pre-heated by the extract air via the integrated aluminium counterflow heat recovery cell. The Sentinel Kinetic Z shall automatically vary the ventilation rate via EC/DC motors, as it receives signals from one of the optional interconnected sensors. When a signal is received, the fans shall either vary their speed proportionally or on a trickle and boost principle.

The unit shall have the facility to commission the supply and extract fans individually via the wired remote control unit. The fans themselves shall have independent, infinitely variable speed control.

Unit specification

The unit shall be manufactured with a galvanized steel outer case construction and shall be suitable for horizontal ceiling void/slab mounting.

The unit shall have a high efficiency aluminium counterflow heat exchanger, supply and extract filters, automatic summer bypass, integral minimum and maximum infinitely variable speed controls with failure indication via the wired remote controller.

The unit shall have low energy, high efficiency EC/DC fan/motor assemblies with sealed for life bearings. The impellers shall be high efficiency backward curved centrifugal type.

The unit shall have a heat exchanger cell with a thermal efficiency of up to 85% when tested to EN 308. This shall be protected by G3 grade synthetic filters on supply and extract. Complete with a condensate drip tray and drain connection.

The unit shall be constructed with a removable access panel allowing full maintenance access from below. The removable panel shall provide access to the following:

- ✓ Supply or extract fan
- ✓ Supply and extract filter
- ✓ Heat exchanger
- ✓ Access to the electrical connections

Access shall be provided for wiring termination and setup/ commissioning. Units shall be as manufactured by Vent-Axia Ltd.

Standard controls

All Sentinel Kinetic Z units shall incorporate the following functions integrally mounted, pre-wired and factory fitted by the manufacturer: -

- ✓ Integral infinitely variable fan speed control on supply and extract.
- ✓ Integral min/max ventilation control/set point.
- ✓ Heating interlocks
- ✓ 0-10V proportional speed adjustment.
- ✓ Volt free contacts
- ✓ 24V sensor supply
- ✓ Integral on/off or trickle boost function from remote switch, e.g. PIR occupancy detector.
- ✓ The unit shall be controlled by the 'Sentinel' control devices (enablers and sensors) as detailed in the schedule or on the drawings.
- ✓ Fully automatic summer bypass
- ✓ Switched Live input with adjustable 'delay-on' feature
- ✓ Fan failure or component failure indicated via individual fault code display.
- ✓ Running time counter
- ✓ Control panel PIN number lock
- ✓ Automatic frost protection effective to -5°C
- ✓ The unit shall incorporate ('H' models) an integral humidity sensor with the following features:
 - Ambient Response; Raises the humidity trigger point as dwelling temperature reduces.
 - Rapid Response: Monitors the rate of change in humidity and triggers increased airflow even if the humidity trigger threshold is not reached.
 - Proportional Response; Incrementally increases the fan speed to reduce noise and reduce energy consumption.

The unit shall be controlled by the 'Sentinel' control devices (enablers and sensors) as detailed in the schedule or on the drawings.

Airflow Direction & Condensate Connection (RH Supplied)

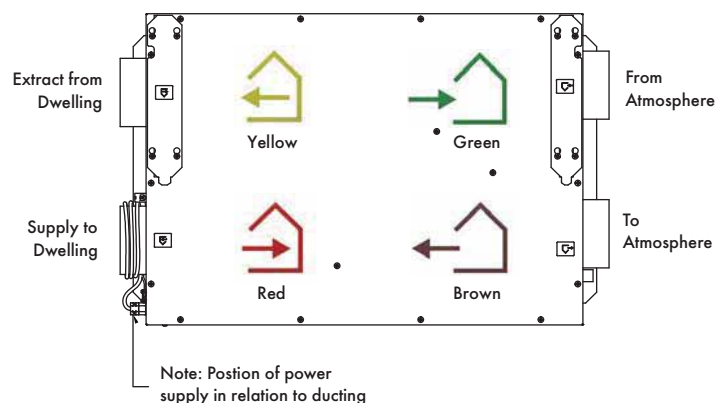



Performance

Fan speeds are fully adjustable within the performance range

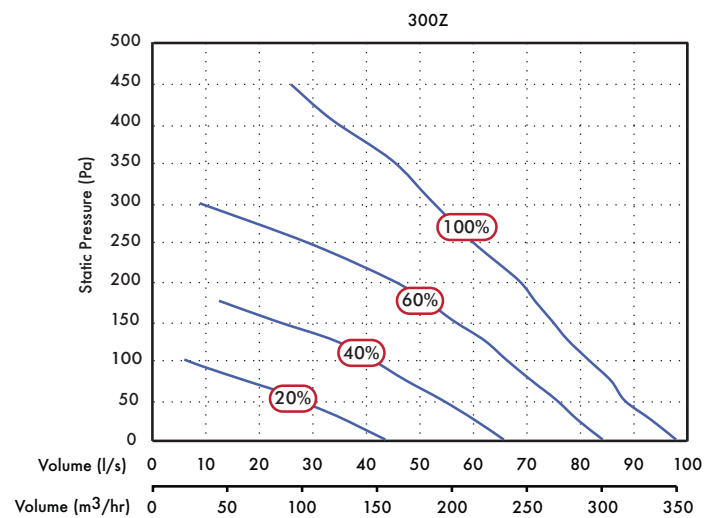
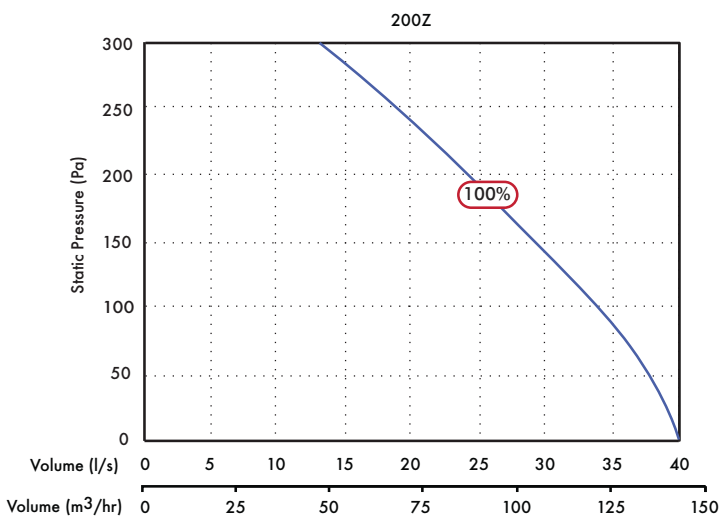

Sound Data - 300Z Model

Flow, l/s	Flow %	Test mode	63	125	250	500	1k	2k	4k	8k	dB(A) at 3m
26	10%	Supply	42.5	42.8	38.3	32.9	28	24.6	25.5	30.3	26.3
		Extract	46.9	45	40.3	34.4	27.4	23	24.3	30.1	22.5
		Breakout	48.7	52.1	47.7	40.5	32.9	27.3	25.1	31.6	24.4
44	20%	Supply	45.6	47	41.7	35.7	31.7	26.7	24.8	30	29.9
		Extract	46.9	48.6	47	38.2	29.5	25.3	23.8	29.9	25.3
		Breakout	50.2	56.4	53.9	46.3	37.5	32.5	25.2	31.4	28.8
55	30%	Supply	44.4	46	52.9	39.4	35.1	31.9	25.5	30.5	33.9
		Extract	47	48	55.5	42.5	32.2	29.9	25.7	30.6	30.6
		Breakout	52.2	59.6	62	51.4	41.9	37.4	28.1	31.4	34.7
66	40%	Supply	43.1	44.4	54.3	43.5	39.2	35.7	27.7	29.9	35.0
		Extract	48.9	49	58.4	45.9	35.7	33.4	25.3	29.9	33.4
		Breakout	54.6	58.3	66.1	52.6	39.3	36.5	31.1	35.3	37.7
85	60%	Supply	44.7	49.8	58	50.4	45	41.9	30.6	30.3	39.1
		Extract	51	53.6	61.2	50.1	41.6	40.1	30.7	31.1	36.7
		Breakout	57.5	62.6	68.7	57.5	45.9	41	36.3	34	40.7
96	80%	Supply	46	52.2	57.1	56.5	47.2	44.2	32.3	30.5	40.5
		Extract	55.5	55	63.1	53.4	44.3	41	33.5	31.4	38.8
		Breakout	62.2	65.7	68.8	63	50.8	43.8	38.8	35.4	42.9
98	100%	Supply	46.6	52.3	57	55.4	47.1	43.7	32.1	30.3	40.1
		Extract	53.7	55.2	63.3	53.3	44.1	41.2	33.2	31.5	38.9
		Breakout	62.2	73.8	77.4	74.1	67.4	61	53.6	45.4	53.9

Tested according to BS848. Breakout quoted spherical. Supply and Extract quoted hemispherical