



MRXBOX95B-LHI/LH2

Mechanical Ventilation Unit with Heat Recovery & Summer Bypass for Loft Mounting

Installation and Maintenance

CE The EMC Directive
2004/108/EC
The Low Voltage
directive
2006/95/EC

1.0 Introduction

IMPORTANT

Unit must not be switched off during normal operation, the product is designed to run continuously.

MRXBOX95B-LHI/LH2 is designed to provide mechanical supply and extract ventilation with heat recovery and incorporates summer bypass.

The unit has the facility to commission the supply and extract fans independently on minimum speed (continuous background ventilation), boost control will control both fans to the same volume.

To recover heat from the extract air the heat exchanger block is utilised. This heat exchanger can recover up to 95% of the normally wasted heat.

The bypass damper opens when a 230V switch signal is applied to the unit (via a manual switch). This opens the damper via a wax actuator. When the switch signal is deactivated the unit returns to its original state (air through the heat exchanger).

Outside air supplied through the bypass is still being filtered, so the air quality is optimal, irrespective of the bypass setting (Open or closed).

Figure 1. Airflow through unit.

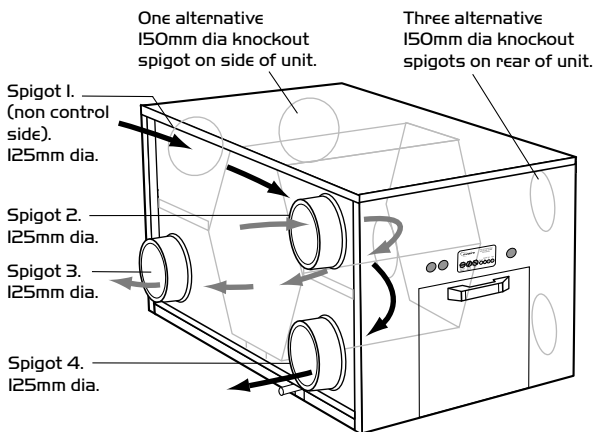

Spigot Location and Ducting references:

- Spigot 1.** Extract air from kitchen/bathroom.
- Spigot 2.** Intake air from outside.
- Spigot 3.** Outside air to house.
- Spigot 4.** Extract air to outside.

2.0 Installation

Installation must be carried out by competent personnel in accordance with the appropriate authority and conforming to all statutory governing regulations.

All mains wiring must be in accordance with the current I.E.E. Regulations, or the appropriate standards. Ensure that the mains supply (Voltage, Frequency and Phase) complies with the rating label.

Please note a clear working space is required around the installed unit to allow the cover to be removed and provide sufficient access for maintenance such as filter change.

The fan must be installed indoors, away from direct sources of frost, heat, water spray or moisture generation.

The unit is designed for mounting on the roof joists in the loft space using four "L shape" metal brackets and four A.V. mounts supplied with the unit. Please note that various positions for the brackets are available to suit different joist centres.

Connect the four 'L' shape fixing brackets to the unit with the M4 screws (provided) they can be attached to the long, or short sides of the unit depending on requirements. Each pair of brackets should be mounted at different heights so the fall is towards the drip tray end of the unit. (see figures 2a, 2b and 2c for fixing details). Lower the unit with the "L" shape fixing brackets attached onto the joists. Mark through the brackets and drill four clearance holes into the top surface of joists.

Locate anti-vibration mounts (supplied) above and below each bracket fixing point hole and, using 4 suitable screws (not provided) and washers, fix the unit to the joists (see fig 2b).

Do not overtighten the fixings. The distance from the top washer on the A.V. mount to the joist when installed must not be less than 30mm.

Figure 2a. Mounting MRXBOX95B-LHI/LH2 onto roof joists using the 'L' shaped fixing brackets and AV mounts with four suitable screws on the long side of the unit.

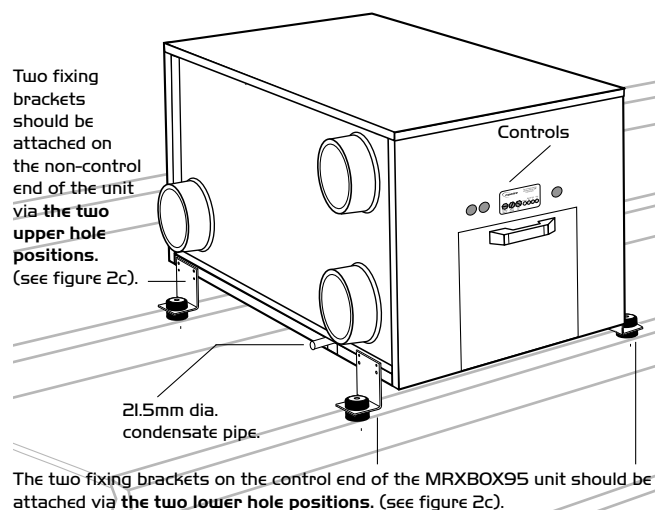

Installation cont.

Figure 2b. Mounting MRXBOX95B-LH1/LH2 onto roof joists using the 'U' shaped fixing brackets and AV mounts with four suitable screws on the short side of the unit.

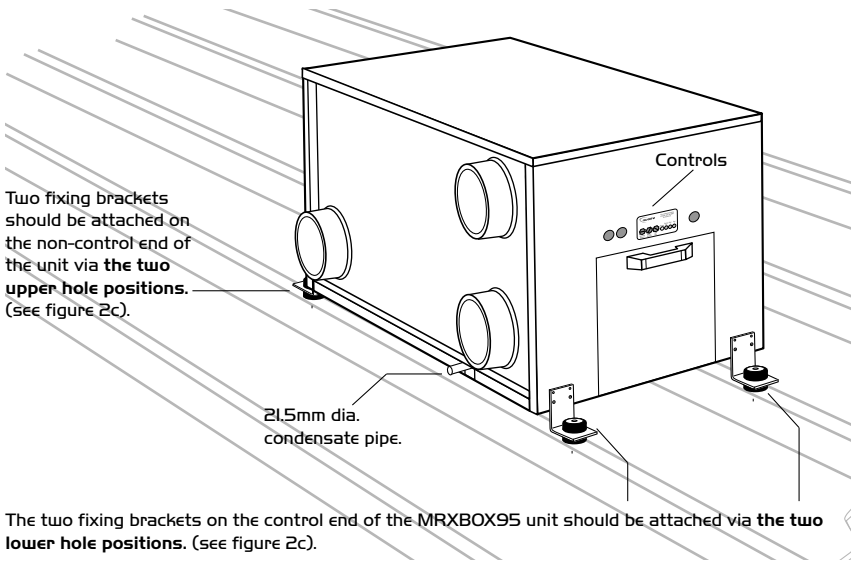

Figure 2c. Side and front view example of an 'U' shaped fixing bracket and AV mount attached to ceiling joist.

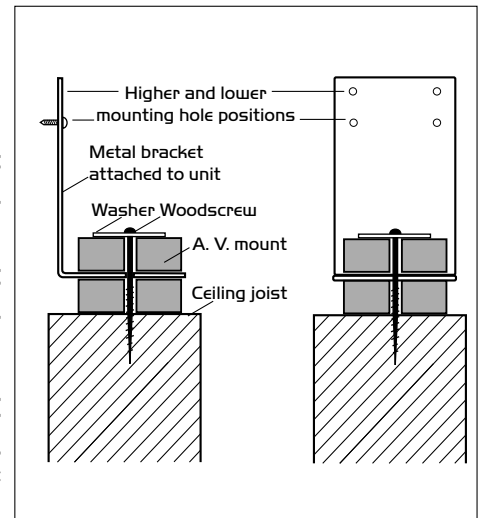
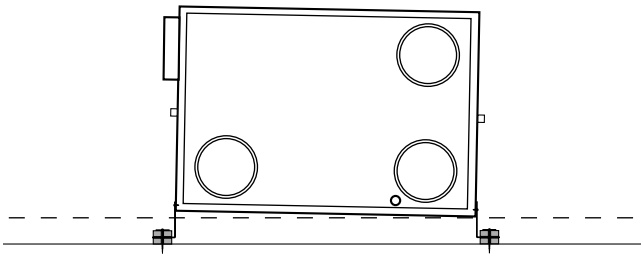

Figure 2d. Unit viewed from the front mounted at a slight angle.



2.1 Condensate Drain

1. Remove top cover and remove heat exchanger.
The condensate outlet can then be seen at the base of the unit. Using a 90 Deg bend and suitable length of 3/4" / 21.5mm diameter overflow pipe (not supplied) take the condensate to the outside of the unit (can be taken to either side of the unit as required).
Suitable adhesive should be used for all connections.
2. The drain should run through a secondary trap before being discharged through the eaves or into the waste water system.
3. Pour a little water into the drip tray to create an air trap.

Figure 3. Plan view of unit showing drip tray and condensate drain.

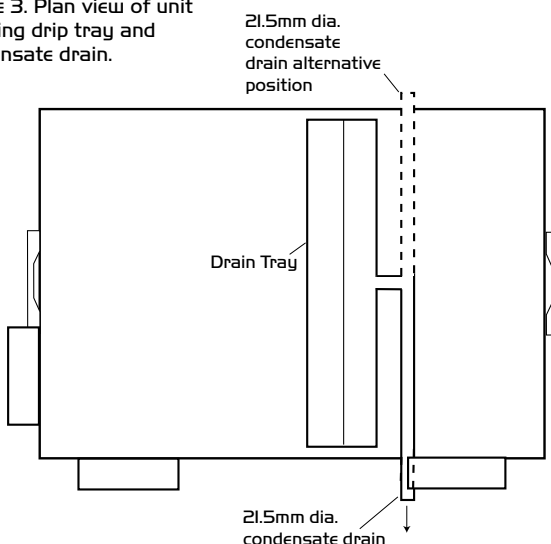

2.2 Extract/input areas

The unit is designed to extract air from all wet rooms e.g. bathroom, kitchen, en-suite, utility room (with sink). WC's do not need to be ventilated if openable windows are fitted. Supply air should be to all habitable rooms e.g. bedrooms and lounge. Extract / input grilles should be adjustable valve types (not supplied).

2.3 Ducting

1. If the unit has been specified as SAP appendix Q installation the use of flexible is prohibited. If flexible ducting is to be used it should be kept to a minimum and should always be pulled taut.
2. The unit is supplied with 150mm and 125mm outlets. It is recommended that 150mm ducting be used from outside to the unit and 125mm used from the unit to the dwelling rooms. To prevent condensation on the ducting they should be insulated externally vapour-proof as far as the unit.
3. Ducting layout plans should be adhered to if available.
4. It is recommended the 204 x 60mm ducting be used and the number of 90 Deg bends be kept to a minimum.
5. Ducting joints must be sealed with duct tape and/or silicone sealant.

For further information refer to Building Regulations Part F and BRE appendix Q website.

IMPORTANT

Any air intake terminal MUST be installed in accordance with the appropriate regulation.

As a guide, the BS5440 series of British Standards deals with this issue and currently states that an air intake must be at a minimum distance of 300mm from a gas boiler balanced flue. Installers are advised to be aware of the requirements of this standard when installing 'through the wall' supply air ducting.

Similarly, supply and extract air grilles should be at least 300mm apart.

Installation cont.

Figure 4. Main unit components shown with front and lid removed.

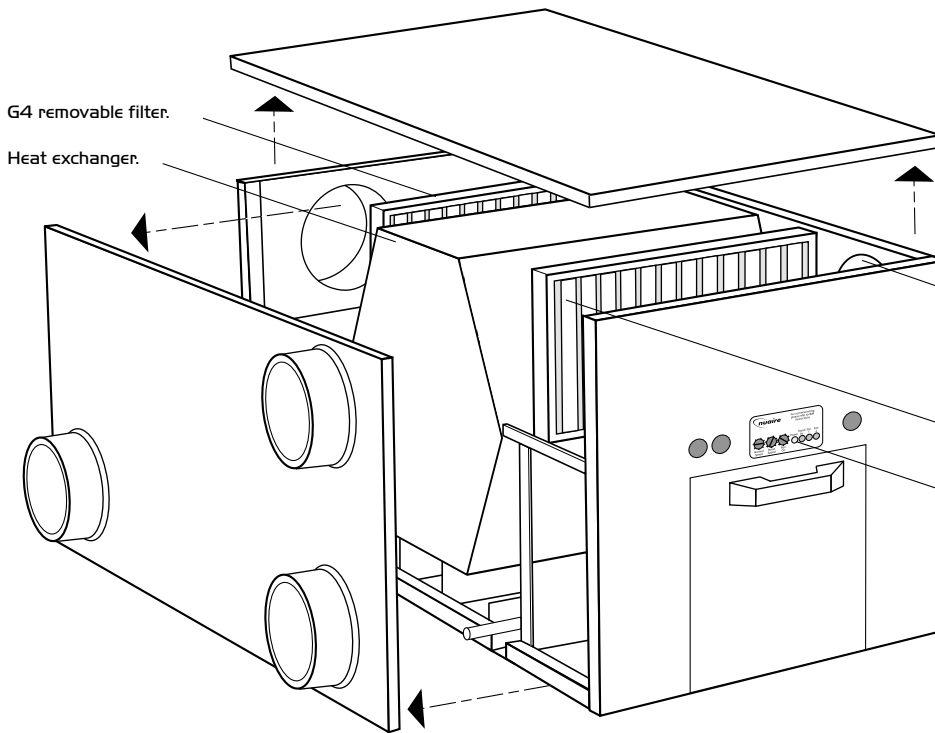
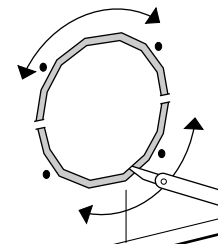

Figure 5.



Three optional 150mm dia. knockout spigot locations on rear of unit and one on the side (non controls). If required for use cut through the acoustic foam round the circumference of the knockout. (see figure 5)

G4 removable filter.

Adjustment potentiometers and indication lights.

3.0 Dimensions (mm)

VIEW FROM FRONT 3 X 125mm spigots

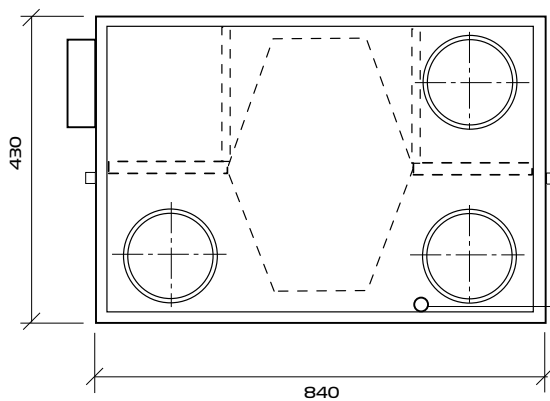

SIDE VIEW (controls)

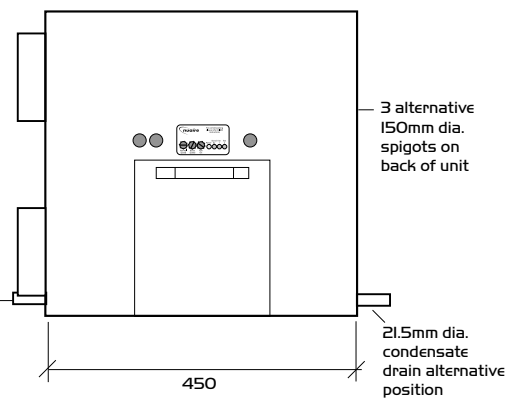

VIEW FROM TOP

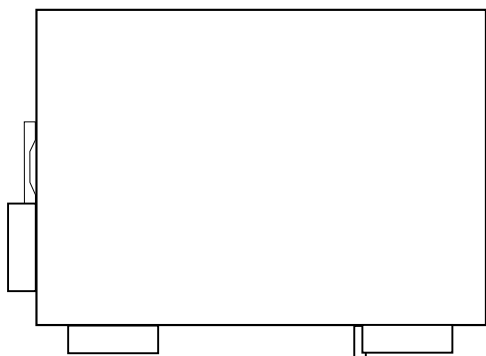

SIDE VIEW (non controls)

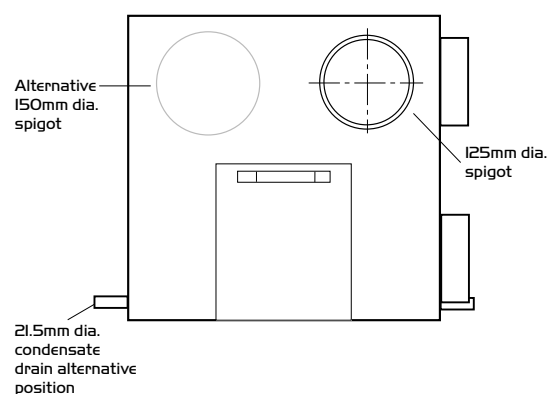

4.0 Electrical Connection

IMPORTANT

For good EMC engineering practice, any sensor cables or switched live cables should not be placed within 50mm of other cables or on the same metal cable tray as other cables.

Please note: the electrical connection of the unit must be carried out by a qualified electrician.

The unit is supplied with a flexible cord for connection to the mains supply.

Electrical details:-

Voltage: 240V 1ph 50Hz

Consumption: LHI - 1.3 Amp

LH2 - 2.2 Amp

Fuse rating: 3 Amp

NOTE This unit must be earthed.

The three core cable from the mains power supply should be connected to a fixed wiring installation, via a fused isolator, in accordance with current IEE wiring regulations.

Figure 6.

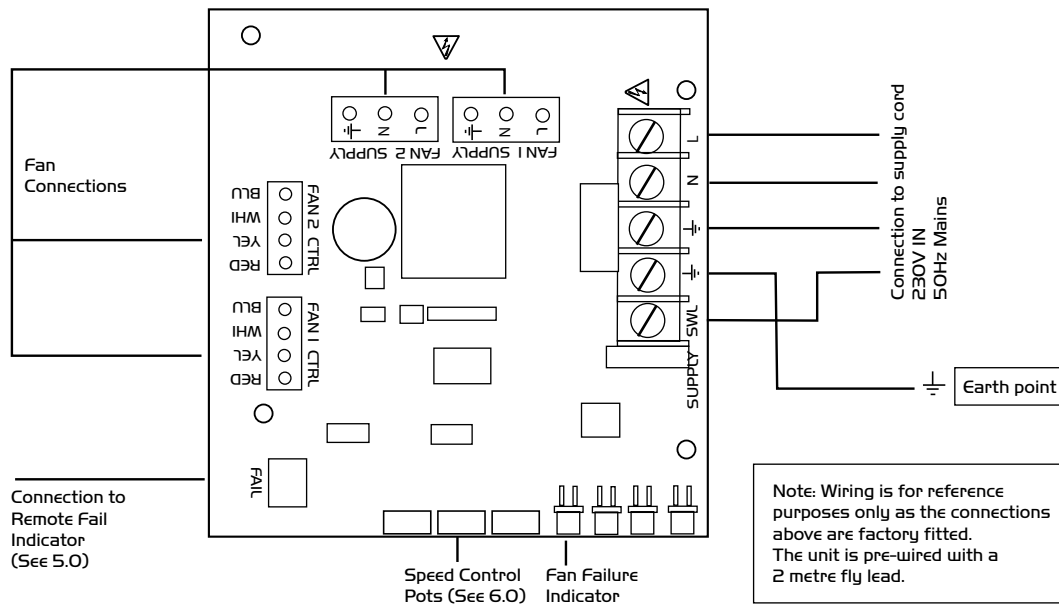

Unit serving kitchen and bathroom

Figure 7a.

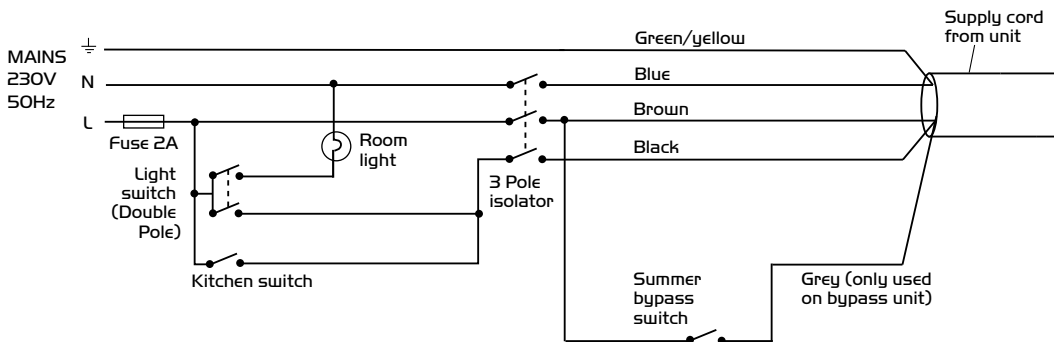

Unit serving kitchen and two bathrooms

Figure 7b.

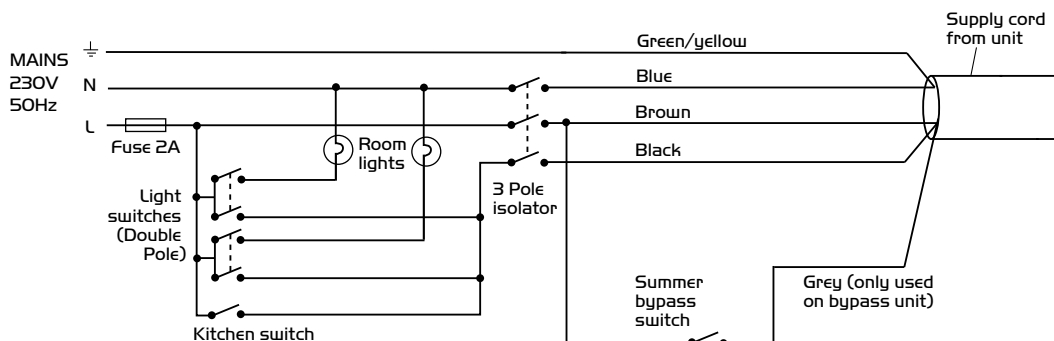

5.0 Ancillaries

Remote Fail Indicator OPUS-RFI

6.0 Commissioning

1. For the required airflow rates refer to the design specification for the property or refer to Building Regulations Part F.
2. The unit is supplied with control of both the normal airflow and boost airflow. (see figure below).
3. Commissioning should be carried out using a moving vane anemometer in conjunction with a hood.
4. Once commissioned the house owner / tenant should be informed that the unit should not be adjusted as it will have a detrimental effect on the indoor air quality and could result in condensation and mould growth.

Figure 8. Detail of unit control on side panel.

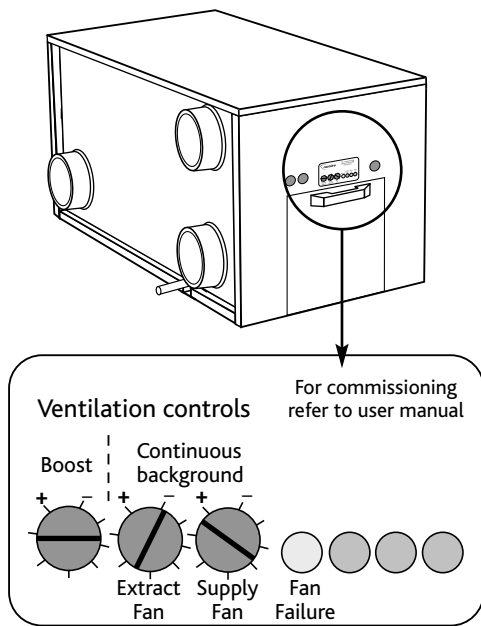

IMPORTANT

Isolation - Before commencing work make sure that the unit, switched live and Nuaire control are electrically isolated from the mains supply and switched live supply.

7.0 Maintenance/Cleaning

Figure 9. Removing filters.

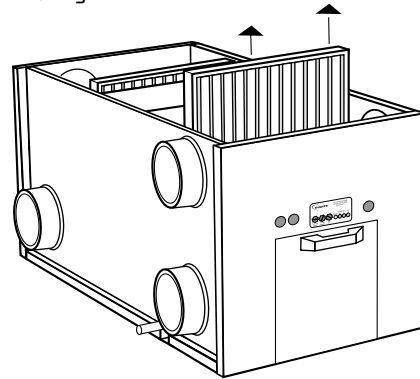

1. **Replace filters every 5 years.** Remove the top cover and slide out the two G4 filters fitted either side of the heat exchanger. Replace with new filters.
2. **Inspect heat exchanger every 5 years.** Generally check for damage and security of components. Refit top cover.
3. **Inspecting motors.** Motors can be accessed through removal side panels.

8.0 Replacement of Parts

Should any component need replacing Nuaire keep extensive stocks for quick delivery. Ensure that the unit is electrically isolated, before carrying out any work. When ordering spare parts, please quote the serial number of the unit and the ARC number of the purchase if possible. **(This information will be available on the fan label).**

9.0 Warranty

The 5 year warranty starts from the day of delivery and includes parts and labour for the first year and parts only for the remaining 4 years. This warranty is conditional on planned maintenance being undertaken.

10.0 Service Enquiries

Nuaire can assist you in all aspects of service. Our service department will be happy to provide any assistance required, initially by telephone and if necessary arrange for an engineer to call.



**Customer Services Department
on 08705 002 555**

DECLARATION OF INCORPORATION AND INFORMATION FOR SAFE INSTALLATION, OPERATION AND MAINTENANCE

We declare that the machinery named below is intended to be assembled with other components to constitute a system of machinery. All parts except for moving parts requiring the correct installation of safety guards comply with the essential requirements of the Machinery Directive. The machinery shall not be put into service until the system has been declared to be in conformity with the provisions of the EC Machinery Directive.

Designation of machinery: MRXBOX95B-LHI/LH2
Machinery Types: Mechanical Ventilation with Heat Recovery and Summer Bypass
Relevant EC Council Directives: 2006/42/EC (Machinery Directive)
Applied Harmonised Standards: BS EN ISO 12100-1, BS EN ISO 12100-2, EN60204-1, BS EN ISO 9001, BS EN ISO 13857
Applied National Standards: BS848 Parts 1, 2.2 and 5

Signature of manufacture representatives:

Name:	Position:	Date:
1) C. Biggs 	Technical Director	29. 12. 09
2) W. Glover 	Manufacturing Director	29. 12. 09



Note: All standards used were current and valid at the date of signature.

CE DECLARATION OF CONFORMITY

We declare that the machine named below conforms to the requirements of EC Council Directives relating to Electromagnetic Compatibility and Safety of Electrical Equipment.

Designation of machinery: MRXBOX95B-LHI/LH2
I & M Serial No.: 671 500
Machinery Types: Mechanical Ventilation with Heat Recovery and Summer Bypass
Relevant EC Council Directives: 2004/108/EC (EMC), 2006/95/EC (Low Voltage Directive)
Applied Harmonised Standards: EN55014-1, EN55014-2, EN61000-3-2, EN61000-3-3, EN60335-2-80
Basis of Self Attestation: Quality Assurance to BS EN ISO 9001 BSI Registered Firm Certificate No. FM 149

Signature of manufacture representatives:

Name:	Position:	Date:
1) C. Biggs 	Technical Director	29. 12. 09
2) W. Glover 	Manufacturing Director	29. 12. 09

Nuaire Ltd,
 Western Industrial Estate,
 Caerphilly CF83 1NA.

Note: All standards used were current and valid at the date of signature.

INFORMATION FOR SAFE INSTALLATION, OPERATION AND MAINTENANCE OF NUAIRE VENTILATION EQUIPMENT

To comply with EC Council Directives 2006/42/EC Machinery Directive and 2004/108/EC (EMC).

To be read in conjunction with the relevant Product Documentation (see 2.1)

1.0 GENERAL

1.1 The equipment referred to in this Declaration of Incorporation is supplied by Nuaire to be assembled into a ventilation system which may or may not include additional components.

The entire system must be considered for safety purposes and it is the responsibility of the installer to ensure that all of the equipment is installed in compliance with the manufacturers recommendations and with due regard to current legislation and codes of practice.

2.0 INFORMATION SUPPLIED WITH THE EQUIPMENT

2.1 Each item of equipment is supplied with a set of documentation which provides the information required for the safe installation and maintenance of the equipment. This may be in the form of a Data sheet and/or Installation and Maintenance instruction.

2.2 Each unit has a rating plate attached to its outer casing. The rating plate provides essential data relating to the equipment such as serial number, unit code and electrical data. Any further data that may be required will be found in the documentation. If any item is unclear or more information is required, contact Nuaire.

2.3 Where warning labels or notices are attached to the unit the instructions given must be adhered to.

3.0 TRANSPORTATION, HANDLING AND STORAGE

3.1 Care must be taken at all times to prevent damage to the equipment. Note that shock to the unit may result in the balance of the impeller being affected.

3.2 When handling the equipment, care should be taken with corners and edges and that the weight distribution within the unit is considered. Lifting gear such as slings or ropes must be arranged so as not to bear on the casing.

3.3 Equipment stored on site prior to installation should be protected from the weather and steps taken to prevent ingress of contaminants.

4.0 OPERATIONAL LIMITS

4.1 It is important that the specified operational limits for the equipment are adhered to e.g. operational air temperature, air borne contaminants and unit orientation.

4.2 Where installation accessories are supplied with the specified equipment eg. wall mounting brackets. They are to be used to support the equipment only. Other system components must have separate provision for support.

4.3 Flanges and connection spigots are provided for the purpose of joining to duct work systems. They must not be used to support the ductwork.

4.4 In the event of RF interference the fan may change speed. This is normal and will have no adverse effect on the fan. The speed will return to normal once the interference has subsided.

5.0 INSTALLATION REQUIREMENTS

In addition to the particular requirements given for the individual product, the following general requirements should be noted.

- 5.1 Where access to any part of equipment which moves, or can become electrically live are not prevented by the equipment panels or by fixed installation detail (eg ducting), then guarding to the appropriate standard must be fitted.
- 5.2 The electrical installation of the equipment must comply with the requirements of the relevant local electrical safety regulations.
- 5.3 For EMC all control and sensor cables should not be placed within 50mm or on the same metal cable tray as 230V switched live, lighting or power cables and any cables not intended for use with this product.

6.0 COMMISSIONING REQUIREMENTS

6.1 General pre-commissioning checks relevant to safe operation consist of the following:

- Ensure that no foreign bodies are present within the fan or casing.
- Check electrical safety. e.g. Insulation and earthing.
- Check guarding of system.
- Check operation of Isolators/Controls.
- Check fastenings for security.

6.2 Other commissioning requirements are given in the relevant product documentation.

7.0 OPERATIONAL REQUIREMENTS

7.1 Equipment access panels must be in place at all times during operation of the unit, and must be secured with the original fastenings.

7.2 If failure of the equipment occurs or is suspected then it should be taken out of service until a competent person can effect repair or examination. (Note that certain ranges of equipment are designed to detect and compensate for fan failure).

8.0 MAINTENANCE REQUIREMENTS

- 8.1 Specific maintenance requirements are given in the relevant product documentation.
- 8.2 It is important that the correct tools are used for the various tasks required.
- 8.3 If the access panels are to be removed for any reason the electrical supply to the unit must be isolated.
- 8.4 A minimum period of two minutes should be allowed after electrical disconnection before access panels are removed. This will allow the impeller to come to rest.
NB: Care should still be taken however since airflow generated at some other point in the system can cause the impeller to "windmill" even when power is not present.
- 8.5 Care should be taken when removing and storing access panels in windy conditions.